

Nose Piece

Applicable models ■ S1500 ■ S1900 ■ S1910 ■ S2900

Measuring application	Model	External view	Applicable stylus	Skid shape	Remarks
Skidless 	DM44026		All	-	<ul style="list-style-type: none"> • Front travel adjustment with adjustment screw • E-DT-SS01A pickup use only

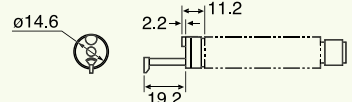

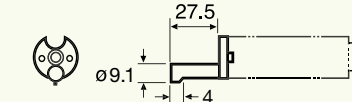
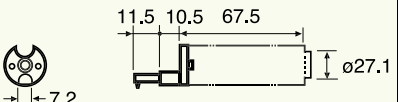
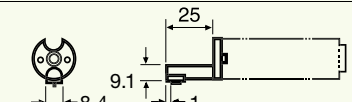
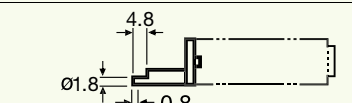
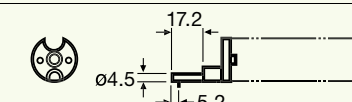
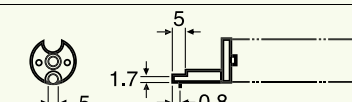
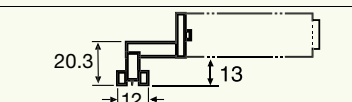
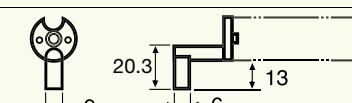
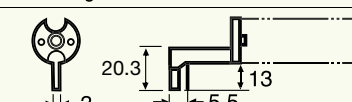
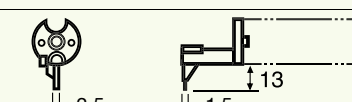
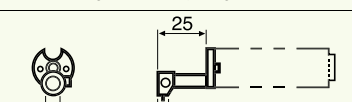
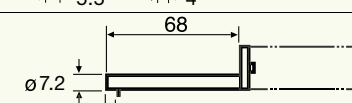
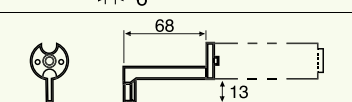
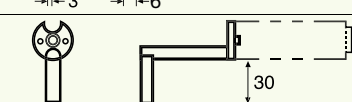
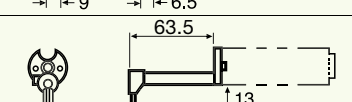







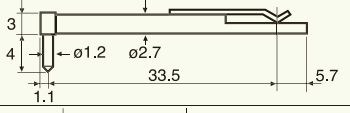

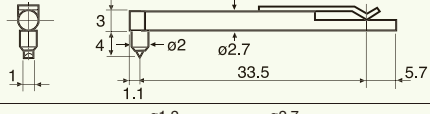

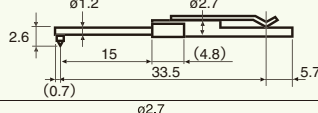

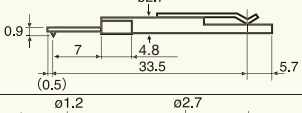

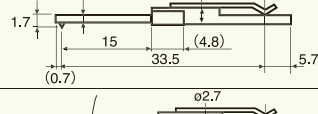

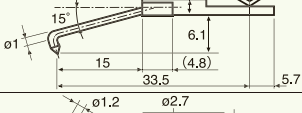
Applicable models ■ FLEX-50 ■ S130 ■ S480 ■ S1400 ■ S1800 ■ S2800

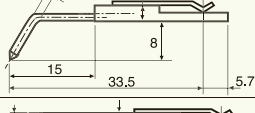
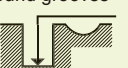
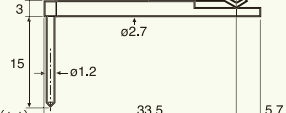
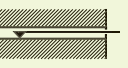
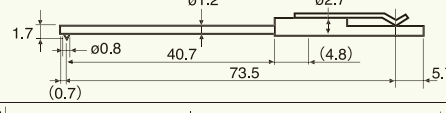
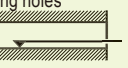
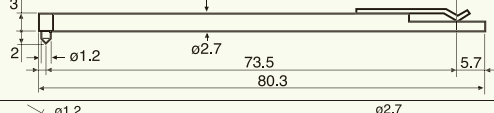
Measuring application	Model	External view	Applicable stylus	Skid shape	Remarks
General purpose	010 2701		010 2501 DM43801	32 mmR sapphire	<ul style="list-style-type: none"> • Tip skid • Standard pickup built in
Skidless	010 2702*		All styluses	-	<ul style="list-style-type: none"> • For protection • For front travel adjustment
Horizontal tracing of ordinary planes	010 2703*		010 2501 DM43801	-	<ul style="list-style-type: none"> • Double sided straddling skid • Skid radius for horizontal tracking: 4.5 mm
Extra fine holes	010 2704		010 2511 DM43811	8 mmR tool steel	<ul style="list-style-type: none"> • Double sided straddling skid • Position adjustment with stylus required
Fine holes	010 2705		010 2512 DM43812	8 mmR tool steel	<ul style="list-style-type: none"> • Tip skid
Thin groove tooth surfaces	010 2706		010 2512 DM43812	8 mmR tool steel	<ul style="list-style-type: none"> • Double sided straddling skid
Curved surfaces	010 2707		010 2515 DM43815	32 mmR sapphire	<ul style="list-style-type: none"> • Sliding skid
Deep grooves	010 2708		010 2515 DM43815	32 mmR sapphire	<ul style="list-style-type: none"> • Double sided straddling skid
Narrow deep grooves	010 2709*		010 2515 DM43815	32 mmR sapphire	<ul style="list-style-type: none"> • Tip skid
R grooves	010 2710*		010 2515 DM43815	0.8 mmR ruby	<ul style="list-style-type: none"> • One sided straddling skid • Magnification: 5,000 or more • Position adjustment with stylus required • Recording only
Small round bars	010 2711		010 2501 DM43801	32 mmR sapphire	<ul style="list-style-type: none"> • Double sided straddling skid • Skid position adjustment required • Three types of skids provided for Φ 2 to 4, Φ 4 to 8, Φ 8 to 16
Long holes	010 2722*		010 2522 DM43822	32 mmR sapphire	<ul style="list-style-type: none"> • Tip skid
Deep grooves in holes	010 2723		010 2525 DM43825	32 mmR sapphire	<ul style="list-style-type: none"> • Tip skid • Position adjustment with stylus required
Extra deep grooves	010 2724		010 2526 DM43826	32 mmR sapphire	<ul style="list-style-type: none"> • Double sided straddling skid • Position adjustment with stylus required
Bottom surface of O-ring grooves	010 2726		010 2525 DM43825	0.8 mmR ruby	<ul style="list-style-type: none"> • Double sided straddling skid • Magnification: 5,000 or more • Position adjustment with stylus required

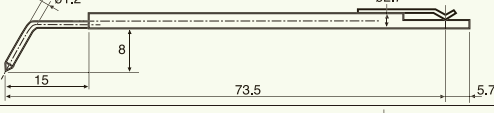
* Indicates stylus/nose piece set DM43800 and 010 2640

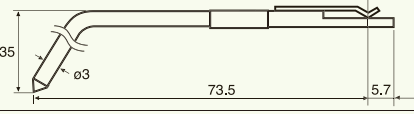
Replaceable Roughness Profile Measuring Styli (Tip Radius 2 µm)

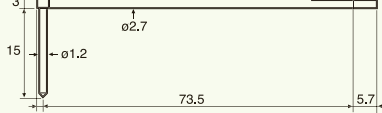

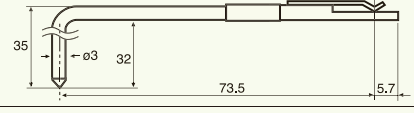
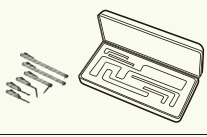
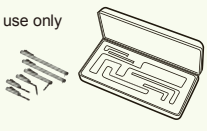







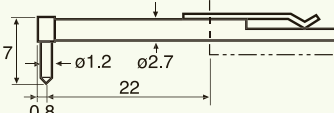

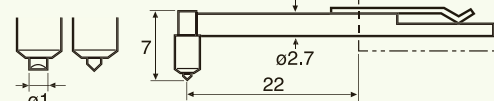

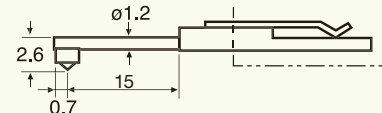

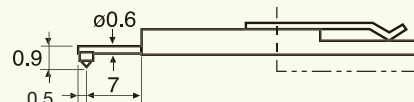

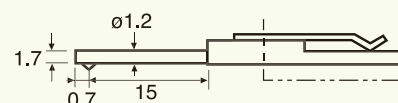

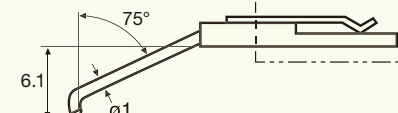

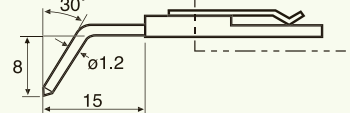

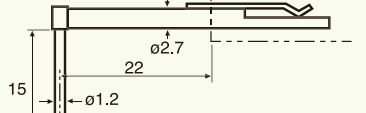
Applicable models ■ FLEX-50 ■ S130 ■ S1400 ■ S1500 ■ S1900 ■ S1910 ■ S480 ■ S1800 ■ S2800 ■ S2900

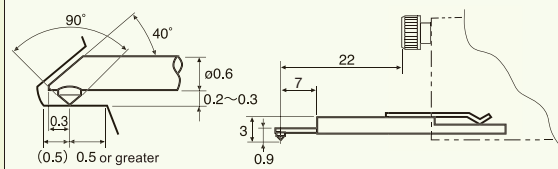
Measuring application	Model	External view	Specifications	Remarks
 General purpose	DM43801		2 µmR, 60° conical diamond, 0.75 mN	<ul style="list-style-type: none"> All orientations Horizontal tracing possible Standard accessory
 Fine wires, knife edges	DM43802		2 µmR, 60° knife edge-shaped diamond, 0.75 mN	<ul style="list-style-type: none"> All orientations
 Medium fine holes	DM43809		2 µmR, 60° conical diamond, 0.75 mN	<ul style="list-style-type: none"> All orientations Horizontal tracing possible
 Extra fine holes, gear flank	DM43811		2 µmR, 60° conical diamond, 0.75 mN	<ul style="list-style-type: none"> All orientations Horizontal tracing possible
 Fine holes/ thin grooves	DM43812*		2 µmR, 60° conical diamond, 0.75 mN	<ul style="list-style-type: none"> All orientations Horizontal tracing possible
 Hole bottom/conical surfaces	DM43813		2 µmR, 60° conical diamond, 0.75 mN	<ul style="list-style-type: none"> All orientations Horizontal tracing possible
 Corners/ tooth surfaces	DM43814*		2 µmR, 60° conical diamond, 0.75 mN	<ul style="list-style-type: none"> All orientations Horizontal tracing possible
 Deep grooves/ round grooves	DM43815*		2 µmR, 60° conical diamond, 0.8 mN	<ul style="list-style-type: none"> Downward measurement Large waveform distortion
 Fine long holes	DM43821		2 µmR, 60° conical diamond, 3 mN	<ul style="list-style-type: none"> Downward measurement Sensitivity: 1/2 Magnification: x5000 Large waveform distortion
 Low magnification, long holes	DM43822*		2 µmR, 60° conical diamond, 3 mN	<ul style="list-style-type: none"> Downward measurement Sensitivity: 1/2 Magnification: x20000
 Low magnification, corners	DM43824		2 µmR, 60° conical diamond, 4 mN	<ul style="list-style-type: none"> Downward measurement Sensitivity: 1/2 Magnification: x20000
 Deep groove corners	DM43827		2 µmR, 60° conical diamond, 4 mN	<ul style="list-style-type: none"> Downward measurement Sensitivity: 1/2 Magnification: x10000
 Deep hole grooves, O-ring groove bottom surfaces	DM43825		2 µmR, 60° conical diamond, 3.4 mN	<ul style="list-style-type: none"> Downward measurement Sensitivity: 1/2 Magnification: x20000 Large waveform distortion
 Extra deep grooves	DM43826		2 µmR, 60° conical diamond, 4 mN	<ul style="list-style-type: none"> Downward measurement Sensitivity: 1/2 Magnification: x5000 Large waveform distortion
Stylus set	DM43800		2 µmR	Nosepiece 010 2702, 010 2703, 010 2709, 010 2710, 010 2722 Stylus DM43812, DM43814, DM43815, DM43822
	DM43900	E-DT-SS01A pickup use only 	2 µmR	Nosepiece DM44026 Stylus DM43801, DM43811, DM43812, DM43814, DM43815, DM43822

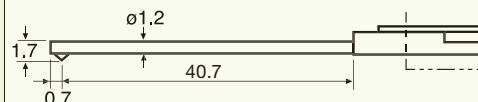
* Indicates stylus/nose piece set DM43800. The value of measuring force is when E-DT-S03A/E-DT-SE19A are mounted.

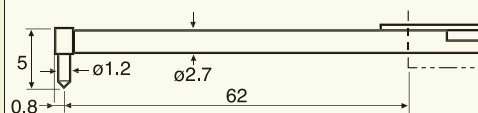
Replaceable Roughness Profile Measuring Styli (Tip Radius 5 μm)

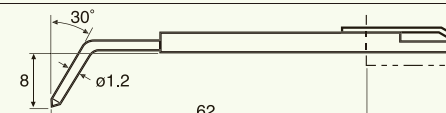
Applicable models ■ FLEX-50 ■ S130 ■ S1400 ■ S1500 ■ S1900 ■ S1910 ■ S480 ■ S1800 ■ S2800 ■ S2900

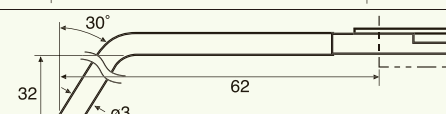
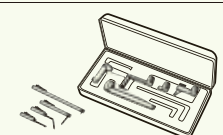





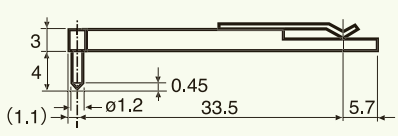

Measuring application	Model	External view	Specifications	Remarks
General purpose 	010 2501		5 μmR, 90°conical diamond, 4 mN	<ul style="list-style-type: none"> All orientations Horizontal tracing possible
Fine wires, knife edges 	010 2502		5 μmR, 90°knife edge-shaped diamond, 5 mN	<ul style="list-style-type: none"> All orientations
Medium fine holes 	010 2509		5 μmR, 90°conical diamond, 4 mN	<ul style="list-style-type: none"> All orientations Horizontal tracing possible
Extra fine holes, gear flank 	010 2511		5 μmR, 90°conical diamond, 4 mN	<ul style="list-style-type: none"> All orientations Horizontal tracing possible
Fine holes/ thin grooves 	010 2512*		5 μmR, 90°conical diamond, 4 mN	<ul style="list-style-type: none"> All orientations Horizontal tracing possible
Hole bottom/ conical surfaces 	010 2513		5 μmR, 90°conical diamond, 4 mN	<ul style="list-style-type: none"> All orientations Horizontal tracing possible
Corners/ tooth surfaces 	010 2514*		5 μmR, 60°conical diamond, 4 mN	<ul style="list-style-type: none"> All orientations Horizontal tracing possible
Deep grooves/ round grooves 	010 2515*		5 μmR, 90°conical diamond, 5 mN	<ul style="list-style-type: none"> Downward measurement Large waveform distortion
Gear tooth profiles, thread flank 	010 2518		5 μmR, 90°conical diamond, 4 mN	<ul style="list-style-type: none"> Magnification: x10000
Fine long holes 	010 2521		5 μmR, 90°conical diamond, 5 mN	<ul style="list-style-type: none"> Downward measurement Sensitivity: 1/2 Magnification: x5000 Large waveform distortion
Low magnification, long holes 	010 2522*		5 μmR, 90°conical diamond, 5 mN	<ul style="list-style-type: none"> Downward measurement Sensitivity: 1/2 Magnification: x20000
Low magnification, corners 	010 2524		5 μmR, 60°conical diamond, 5 mN	<ul style="list-style-type: none"> Downward measurement Sensitivity: 1/2 Magnification: x20000
Deep groove corners 	010 2527		5 μmR, 60°conical diamond, 8 mN	<ul style="list-style-type: none"> Downward measurement Sensitivity: 1/2 Magnification: x10000 Large waveform distortion
Stylus set 	010 2640		5 μmR	Nosepiece 010 2702, 010 2703, 010 2709, 010 2710, 010 2722 Stylus 010 2512, 010 2514, 010 2515, 010 2522

* Indicates stylus/nose piece set 010 2640. The value of measuring force is when E-DT-S01A/E-DT-SE18A are mounted

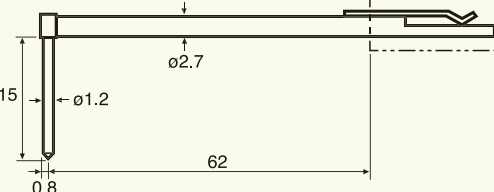
Standard Inventory Parts

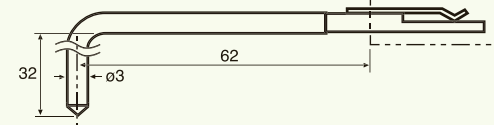
Replaceable Roughness Profile Measuring Styli

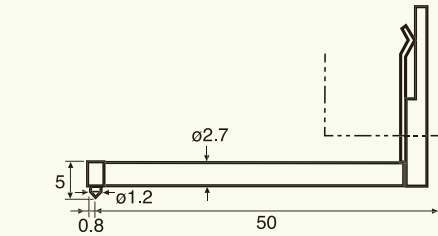
Applicable models ■ FLEX-50 ■ S130 ■ S1400 ■ S1500 ■ S1900 ■ S1910 ■ S480 ■ S1800 ■ S2800 ■ S2900

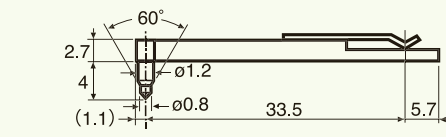
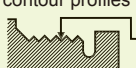
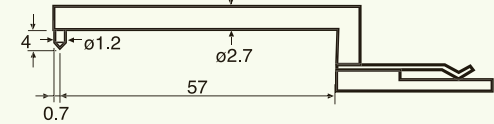



Measuring application	Model	External view	Specifications	Remarks
Soft materials 	010 2508		10 μ mR, 90° conical diamond, 0.75 mN	<ul style="list-style-type: none"> • All orientations • Horizontal tracing possible • Specifications are for when E-DT-S02A is mounted
Deep hole grooves, bottom surface of Oring groove 	010 2525		10 μ mR, 90° conical diamond, 8 mN	<ul style="list-style-type: none"> • Downward measurements • Sensitivity: 1/2 • Magnification: x20000 • Large waveform distortion
Extra deep grooves 	010 2526		10 μ mR, 90° conical diamond, 8 mN	<ul style="list-style-type: none"> • Downward measurements • Sensitivity: 1/2 • Magnification: x5000 • Large waveform distortion
Bottom surface of holes 	010 2541		5 μ mR, 90° conical diamond, 8 mN	<ul style="list-style-type: none"> • Magnification: x5000 • Large waveform distortion • Dedicated connecting rod used
High magnification measurement 	010 2506		1 μ mR, 60° conical diamond, 0.75 mN	<ul style="list-style-type: none"> • All orientations • Horizontal tracing possible • Specifications are for when E-DT-S04A is mounted.
High magnification contour profiles 	010 2528		1 μ mR, 60° conical diamond, 8 mN	<ul style="list-style-type: none"> • Downward measurements • Sensitivity: 1/2 • Magnification: x10000 • For E-DT-S01A, -S03A

* The value of measuring force is when E-DT-S01A/E-DT-SE18A are mounted

 Standard Inventory Parts

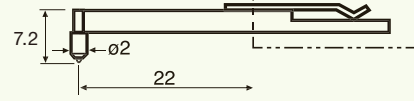
Replaceable Waviness Profile Measuring Styli

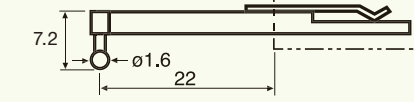
Applicable models ■ FLEX-50 ■ S130 ■ S1400 ■ S1500 ■ S1900 ■ S1910 ■ S480 ■ S1800 ■ S2800 ■ S2900

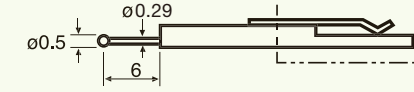
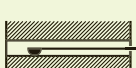
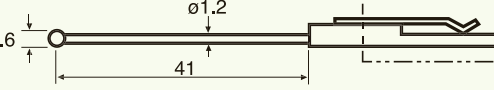
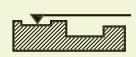
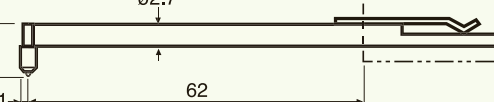
Measuring application	Model	External view	Specifications	Remarks
Steps 	010 2504		250 μ mR, 60° conical sapphire, 5 mN	<ul style="list-style-type: none"> • All orientations
Waviness 	010 2505		Φ 1.6, ruby, 4 mN	<ul style="list-style-type: none"> • All orientations
Extra fine hole profiles 	010 2510		Φ 0.5, tool steel, 4 mN	<ul style="list-style-type: none"> • All orientations • Magnification: x5000 • Excluding E-DT-S03A/ -SS01A/SE19A
Fine long hole waviness 	010 2520		Φ 1.6, ruby, 5 mN	<ul style="list-style-type: none"> • Downward measuring • Sensitivity: 1/2 • Magnification: x10000
Large steps 	010 2523		250 μ mR, sapphire, 5 mN	<ul style="list-style-type: none"> • Downward measuring • Sensitivity: 1/2 • Magnification: x25000

* The value of measuring force is when E-DT-S01A/E-DT-SE18A are mounted

 Standard Inventory Parts

Pickups

Applicable models ■ FLEX-50 ■ S130 ■ S1400 ■ S1500 ■ S1900 ■ S1910 ■ S480 ■ S1800 ■ S2800 ■ S2900

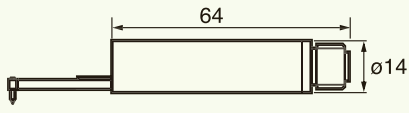
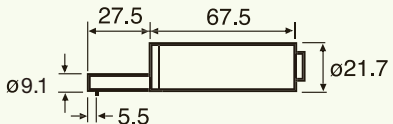
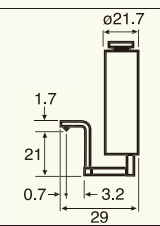
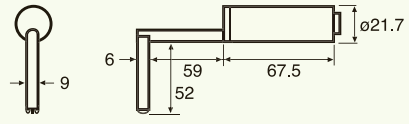
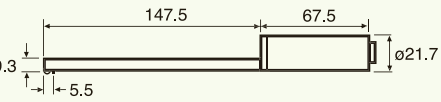
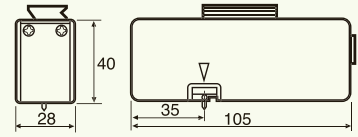
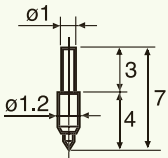
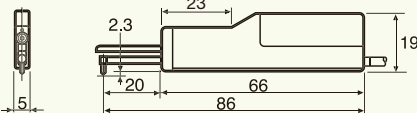
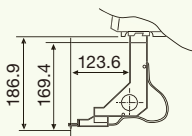
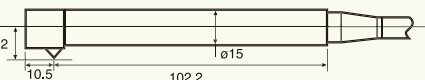
Measuring application	Model	External view	Specifications	Remarks
Low measuring force	E-DT-SS01A		2 µmR, 60° conical diamond, 0.75 mN	<ul style="list-style-type: none"> All orientations Horizontal tracing possible Provided as standard S1500, S1900, S1910, S2900 With DM43801 stylus
General purpose	E-DT-SS08A	For S1500, S1900, and S2900 DX/SD types	5 µmR, 90° conical diamond, 4 mN	<ul style="list-style-type: none"> All orientations Horizontal tracing possible With 0102501 stylus
General purpose	E-DT-S01A E-DT-SE18A		5 µmR, 90° conical diamond, 4 mN	<ul style="list-style-type: none"> All orientations Horizontal tracing possible With 0102501 stylus E-DT-SE18A: for S130A/S-FLEX50A
Soft materials	E-DT-S02A		10 µmR, 90° conical diamond, 0.75 mN	<ul style="list-style-type: none"> All orientations Horizontal tracing possible With 0102508 stylus
Low measuring force	E-DT-S03A E-DT-SE19A		2 µmR, 60° conical diamond, 0.75 mN	<ul style="list-style-type: none"> All orientations Horizontal tracing possible Standard specifications With DM43801 stylus E-DT-SE19A: for S130A/S-FLEX50A
High magnification	E-DT-S04A		1 µmR, 60° conical diamond, 0.75 mN	<ul style="list-style-type: none"> All orientations Horizontal tracing possible With 0102506 stylus
Non-continuous measurement	E-DT-S05A		5 µmR, 90° conical diamond, 4 mN	<ul style="list-style-type: none"> All orientations Horizontal tracing possible Front travel: 110 to 120 µm Other specifications are same as for E-DT-S01A
Grooves in holes	E-DT-S06A		5 µmR, 90° conical diamond, 4 mN	<ul style="list-style-type: none"> Skidless measurement only Max. magnification: x10000 Dedicated connecting rod required (010 2746) With 0102542 dedicated stylus
Ultra deep grooves	E-DT-S07A		5 µmR, 90° conical diamond, 5 mN	<ul style="list-style-type: none"> Stylus can not be replaced Max. magnification: x10000 Sensitivity: 1/2 Large waveform distortion
	E-DT-S122A		2 µmR, 60° conical diamond, 4 mN	
Ultra long holes	E-DT-S08A		5 µmR, 90° conical diamond, 4 mN	<ul style="list-style-type: none"> Stylus can not be replaced Max. magnification: x5000 Sensitivity: 1/5
	E-DT-S137A		2 µmR, 60° conical diamond, 4 mN	
High magnification	E-DT-SH01A			<ul style="list-style-type: none"> Max. magnification: x500000 Measuring force: 0.2 mN With 016 2854 stylus
Stylus for E-DT-SH01A	0162854		1 µmR, 90° conical diamond	<ul style="list-style-type: none"> Included with E-DT-SH01A as standard
	010 2567		1 µmR, 60° conical diamond	
	010 2210		10 µmR, 60° conical diamond	
	010 2211		5 µmR, 60° conical diamond	
	010 2212		0.5 µmR, 60° conical diamond	
	010 2213		0.5 µmR, 90° 2.5 µm width knife edge, diamond	
Thin pickup	DM42001 DM42011 DM42012		5 µmR, 90° conical diamond 10 mN, horizontal tracing possible Max. magnification: x5000 or less	<ul style="list-style-type: none"> With 0102501 dedicated stylus DM42001: for S1400, S1800, S2800 DM42011: for S480 DM42012: for models preceding S590A DM42020: for Linear Series/NEX Series
Pickup holder for thin pickup	E-DH-S60A			<ul style="list-style-type: none"> Used for horizontal tracing of crankshaft pins, journals, or other such parts.
Non-contact measurement	E-DT-SL12B		Measuring range: 300 µm Spot diameter: 2 µm Work distance: 4.5 mm	<ul style="list-style-type: none"> Color confocal point type Light source: Halogen light bulb Life: 1000h

SURFCOM: CONTOURRECORD Option

Replaceable Styli for S5000DX/S3000/SNEX

Applicable models ■ S5000DX/SD ■ S3000A ■ SNEX100

Name	Model	External view	Specifications	Remarks
General purpose	DM48505		2 μmR, 60° conical diamond, 0.75 mN	<ul style="list-style-type: none"> Stroke: 13 mm (S5000) 12mm (S3000) 5mm (S-NEX 100) For roughness and contour measurement
General purpose highly rigid stylus	DM48507		2 μmR, 60° conical diamond, 0.75 mN	<ul style="list-style-type: none"> Stroke: 13 mm (S5000) 12mm (S3000) 5mm (S-NEX 100) For roughness and contour measurement S5000DX/SD standard accessory
Highly rigid stylus for contours 2X arm	DM48508		Φ 1 ruby ball, 0.75 mN	<ul style="list-style-type: none"> Stroke: 26 mm (S5000) 24mm (S3000) 10mm (S-NEX 100) For contour measurement only
Highly rigid stylus for contours 2.5X arm	DM48509		Φ 1 ruby ball, 3.2 mN	<ul style="list-style-type: none"> Stroke: 32.5 mm (S5000) 30mm (S3000) 12.5mm (S-NEX 100) For contour measurement only
Offset measurement stylus	DM48511		2 μmR, 60° conical diamond, 0.75 mN	<ul style="list-style-type: none"> Stroke: 13 mm (S5000) 12mm (S3000) 5mm (S-NEX 100) For roughness and contour measurement
Offset measurement stylus 2X arm	DM48742		25 μmR, 24° conical carbide, 4 mN or less	<ul style="list-style-type: none"> Stroke: 26 mm (S5000) 24mm (S3000) 10mm (S-NEX 100) For contour measurement only
Small hole stylus	DM48513*1		2 μmR, 60° conical diamond, 0.75 mN	<ul style="list-style-type: none"> Stroke: 13 mm (S5000) 12mm (S3000) 5mm (S-NEX 100) For roughness and contour measurement
Extra small hole stylus	DM48514		2 μmR, 60° conical diamond, 0.75 mN	<ul style="list-style-type: none"> Stroke: 13 mm (S5000) 12mm (S3000) 5mm (S-NEX 100) For roughness and contour measurement
Deep hole stylus	DM48515		2 μmR, 60° conical diamond, 0.75 mN	<ul style="list-style-type: none"> Stroke: 13 mm (S5000) 12mm (S3000) 5mm (S-NEX 100) For roughness and contour measurement
Stylus for fine contours	DM48588		5 μmR, 30° conical diamond, 0.75 mN	<ul style="list-style-type: none"> Stroke: 13 mm (S5000) 12mm (S3000) 5mm (S-NEX 100) For roughness and contour measurement
Stylus for ridge/tooth tip measurement	DM48774		2 μmR, 60° knife edge-shaped diamond, 0.75 mN	<ul style="list-style-type: none"> Stroke: 13 mm (S5000) 12mm (S3000) 5mm (S-NEX 100) For roughness and contour measurement

*1 Requires master ball calibration unit for small holes.

*Special stylus will be studied and proposed in accordance with customer's workpieces.

Replaceable Styli for S2000DX/SD

Applicable models ■ S2000DX/SD

Name	Model	External view	Specifications	Remarks	
General purpose	DM47501		2 μmR, 60° conical diamond, 0.75 mN	<ul style="list-style-type: none"> Standard accessory Stroke: 5 mm For roughness and contour measurement 	
	DM47508		5 μmR, 30° conical diamond, 0.75 mN	<ul style="list-style-type: none"> Stroke: 5 mm For roughness and contour measurement 	
	DM47548		5 μmR, 40° conical diamond, 4 mN	<ul style="list-style-type: none"> Stroke: 5 mm For roughness and contour measurement 	
Contour stylus 2X arm	DM47513		LH = 130, LV = -21.5	25 μmR, 24° conical carbide, 5 mN	<ul style="list-style-type: none"> Standard accessory Stroke: 10 mm For contour measurement only
	DM47525		LH = 130, LV = -21.5	25 μmR, 12° inclined carbide, 7 mN or less	<ul style="list-style-type: none"> Stroke: 10 mm For contour measurement only
Offset measurement stylus	DM47504		LH = 65, LV = -14.5	2 μmR, 60° conical diamond, 0.75 mN	<ul style="list-style-type: none"> Stroke: 5 mm Offset: 13.5 mm For roughness and contour measurement
Small hole stylus	DM47505 ^{*1}		LH = 65, LV = -5.025	2 μmR, 60° conical diamond, 0.75 mN	<ul style="list-style-type: none"> Stroke: 5 mm For roughness and contour measurement
	DM47524		LH = 65, LV = -5.7	2 μmR, 60° conical diamond, 0.75 mN	<ul style="list-style-type: none"> Stroke: 5 mm For roughness measurement only
Small hole stylus 2X arm	DM47546 ^{*1}		LH = 65, LV = -5.025	2 μmR, 60° conical diamond, 3 mN or less	<ul style="list-style-type: none"> Stroke: 10 mm For roughness and contour measurement
Extra small hole stylus	DM47506 ^{*1}		LH = 65, LV = -4.625	2 μmR, 60° conical diamond, 0.75 mN	<ul style="list-style-type: none"> Stroke: 5 mm For roughness and contour measurement
Deep groove stylus	DM47507		LH = 65, LV = -30.5	2 μmR, 60° conical diamond, 0.75 mN	<ul style="list-style-type: none"> Stroke: 5 mm For roughness and contour measurement
	DM47549		5 μmR, 90° conical diamond, 4 mN	<ul style="list-style-type: none"> Stroke: 5 mm For roughness and contour measurement 	
	DM47572		2 μmR, 60° conical diamond, 2 mN or less	<ul style="list-style-type: none"> Stroke: 5 mm For roughness and contour measurement 	
General purpose stylus 2X arm	DM47547		LH = 130, LV = -15.5	2 μmR, 60° conical diamond, 4 mN	<ul style="list-style-type: none"> Stroke: 10 mm For roughness and contour measurement
Corner/tooth surface stylus	DM47523		LH = 65, LV = -12.525	2 μmR, 60° conical diamond, 0.75 mN	<ul style="list-style-type: none"> Stroke: 5 mm For roughness measurement only
Corner/tooth surface stylus 2X arm	DM47595		LH = 130, LV = -13.5	2 μmR, 60° conical diamond, 4 mN or less	<ul style="list-style-type: none"> Stroke: 10 mm For roughness measurement only
Stylus for ridge/tooth tip measurement	DM47551		LH = 65, LV = -8.35	2 μmR, 60° knife edge-shaped diamond, 0.75 mN	<ul style="list-style-type: none"> Stroke: 5 mm For roughness and contour measurement
Stylus for waviness measurement	DM47540		LH = 65, LV = -14.35	Φ 2 ruby ball, 0.75 mN	<ul style="list-style-type: none"> Stroke: 5 mm For contour (waviness) measurement

*Requires master ball calibration unit for small holes. *Special stylus will be studied and proposed in accordance with customer's workpieces.



Standard Inventory Parts

Contour Styli

*See page 74 to 75 for the details of stylus/arm for C1710/S1910.

Applicable models ■ C1600 ■ C1700 ■ S1800 ■ S1900

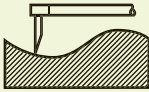
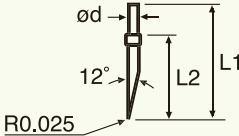
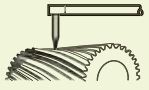
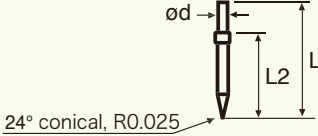
Stylus material: Cemented carbide

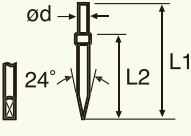
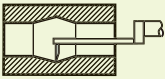
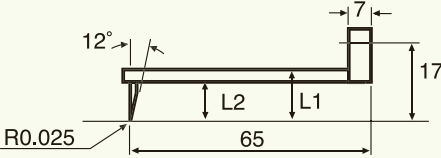
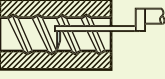
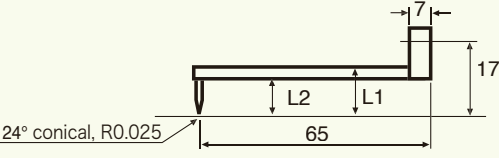
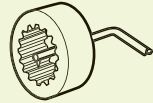
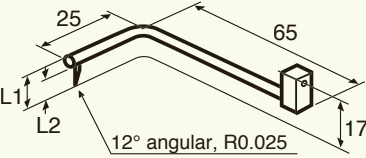
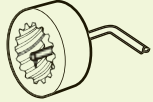
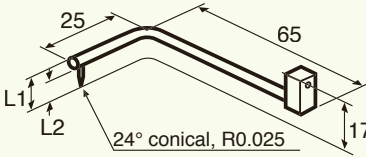
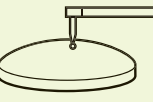
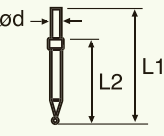
Measuring application	Model	External view	d	L1	L2	Applicable arm	Remarks	
 General purpose	DM45501 *2		3	60	52	010 2804		
	DM45502		3	34	26	010 2800		
	DM45503		2	21	13	010 2801		
 General purpose	DM45504 *2		3	60	52	010 2804	• Standard accessory	
	DM45505 ※		3	34	26	010 2800		
	DM45506		2	21	13	010 2801		
 Edge line	DM45507 *2		3	60	52	010 2804		
	DM45508 ※		3	34	26	010 2800		
	DM45509		2	21	13	010 2801		
 Small holes	DM45081		—	12	9	010 2802		
	DM45082		—	7	5			
	DM45083 *1		—	3.5	1.5			
 Small hole twist	DM45084 ※		—	12	9	010 2802		
	DM45085		—	7	5			
	DM45086 ※*1		—	3.5	1.5			
 Ordinary offset	DM45087		—	12	9	010 2802	• Offset: 25 mm	
	DM45088		—	7	5			
	DM45089 *1		—	3.5	1.5			
 Helix surface offset	DM45090		—	12	9	010 2802	• Offset: 25 mm	
	DM45091		—	7	5			
	DM45092 *1		—	3.5	1.5			
 High precision	DM45522 *2		3	60	52	010 2804	• Φ 0.7 ruby ball	
	DM45523		3	34	26	010 2800		
	DM45524		2	21	13	010 2801		
	DM45525 *2		3	60	52	010 2804		
	DM45526		3	34	26	010 2800		• Φ 1 ruby ball
	DM45527		2	21	13	010 2801		

※ Indicates stylus/arm set 010 2999

*1:Requires master ball calibration unit for small holes. *2:Requires pickup holder joint

Standard Inventory Parts

Contour Detectors and Arms

*See page 74 to 75 for the details of stylus/arm for C1710/S1910.

Applicable models ■ C1600 ■ C1700 ■ S1800 ■ S1900

Measuring application	Model	External view	Applicable arm	Remarks
Contour detector	E-DT-CE02A		—	• C1600, S1800D/G
	E-DT-CE03		—	• C1700DX/SD, S1900DX/SD
General purpose	010 2800		DM45502 DM45505 DM45508 DM45523 DM45526	
Inner surface	010 2801		DM45503 DM45506 DM45509 DM45524 DM45527	
Small holes	010 2802 ※		DM45081 to DM45092	
Deep grooves	010 2804		DM45501 DM45504 DM45507 DM45522 DM45525	<ul style="list-style-type: none"> • Max. magnification: x50 • 010 2744 pickup holder coupling required • Provided with auxiliary weight
Offset measurement	010 2805		DM45502 DM45505 DM45508 DM45523 DM45526	<ul style="list-style-type: none"> • Max. magnification: x100 • Offset: 50 mm • Provided with auxiliary weight
	010 2806		DM45502 DM45505 DM45508 DM45523 DM45526	<ul style="list-style-type: none"> • Max. magnification: x50 • Offset: 100 mm • Provided with auxiliary weight
	010 2807		DM45503 DM45506 DM45509 DM45524 DM45527	<ul style="list-style-type: none"> • Max. magnification: x100 • Offset: 50 mm • Provided with auxiliary weight
Long items	010 2808		DM45501 DM45504 DM45507 DM45522 DM45525	<ul style="list-style-type: none"> • Max. magnification: x10 • Lever movement range: 100 mm • Sensitivity: 1/2 • Provided with auxiliary weight • 010 2744 pickup holder coupling required
Long holes	010 2810		DM45503 DM45506 DM45509 DM45524 DM45527	<ul style="list-style-type: none"> • Max. magnification: x25 • Lever movement range: 100 mm • Sensitivity: 1/2 • Provided with auxiliary weight
Arm/stylus set	010 2999			Stylus : DM45505, DM45508, DM45084, DM45086 Arms : 010 2802, 010 2805





※ Indicates stylus/arm set 010 2999

Standard Inventory Parts

Contour Styli

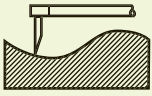
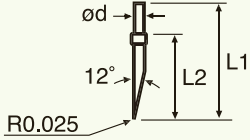
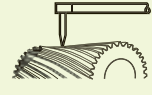
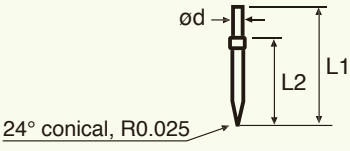
Applicable models ■ C1710 ■ C2600 ■ C2700 ■ S1910 ■ S2800 ■ S2900

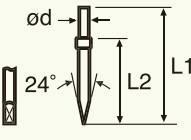
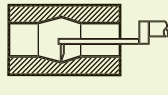
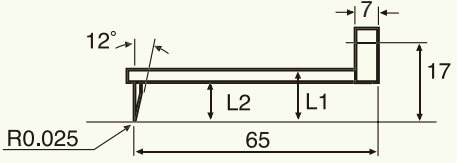
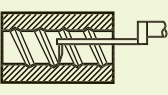
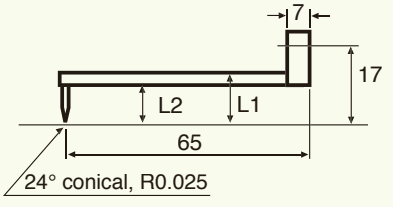
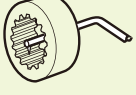
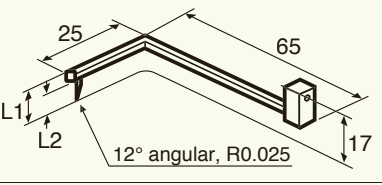
Stylus material: Cemented carbide

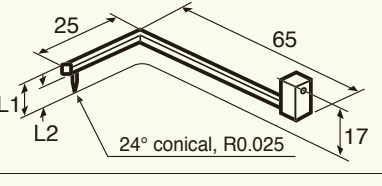
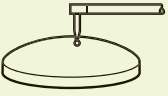
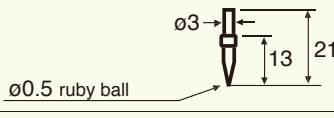
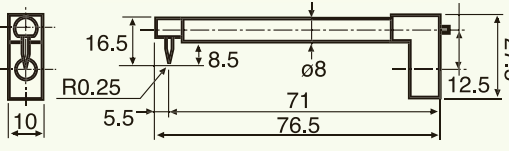
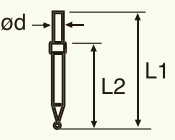
Measuring application	Model	External view	d	L1	L2	Applicable arm	Remarks
 General purpose	DM45501		3	60	52	DM45531	
	DM45502		3	34	26	DM45528	
	DM45503		2	21	13	DM45529	
 General purpose	DM45504		3	60	52	DM45531	• Standard accessory: DM45505
	DM45505 ※		3	34	26	DM45528	
	DM45506		2	21	13	DM45529	
 Edge line	DM45507		3	60	52	DM45531	
	DM45508 ※		3	34	26	DM45528	
	DM45509		2	21	13	DM45529	
 Small holes	DM45510		–	12	9	DM45530	• Measuring force: 10 mN or less • Deflection: Approx. 1.5 µm for 10 mN
	DM45511		–	8	5		
	DM45512 *1		–	4.5	1.5		
 Small hole twist	DM45513 ※		–	12	9	DM45530	• Measuring force: 10 mN or less • Deflection: Approx. 1.5 µm for 10 mN
	DM45514		–	8	5		
	DM45515 ※*1		–	4.5	1.5		
 Ordinary offset	DM45516		–	12	9	DM45530	• Measuring force: 10 mN or less • Deflection: Approx. 3 µm for 10 mN
	DM45517		–	8	5		
	DM45518 *1		–	4.5	1.5		
 Helix surface offset	DM45519		–	12	9	DM45530	• Measuring force: 10 mN or less • Deflection: Approx. 3 µm for 10 mN
	DM45520		–	8	5		
	DM45521 *1		–	4.5	1.5		
 High precision	DM45580		3	21	13	DM45733	• Φ 0.5 ruby ball
	DM45583		–	16.5	8.5	–	• Φ 0.5 ruby ball • Integrated with arm
	DM45522		3	60	52	DM45531	• Φ 0.7 ruby ball
	DM45523		3	34	26	DM45528	
	DM45524		2	21	13	DM45529	
	DM45525		3	60	52	DM45531	
DM45526	3		34	26	DM45528		
DM45527	2	21	13	DM45529	• Φ 1 ruby ball		

※ Indicates stylus/arm set DM45500

*1: Requires master ball calibration unit for small holes.

Contour Detectors and Arms

Applicable models ■ C1710 ■ C2600 ■ C2700 ■ S1910 ■ S2800 ■ S2900

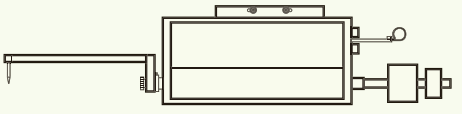
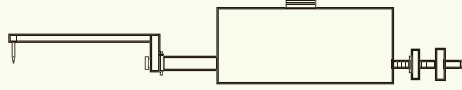
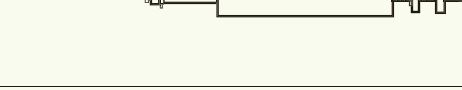
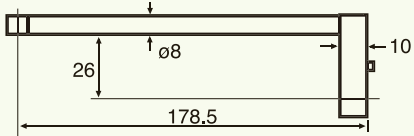
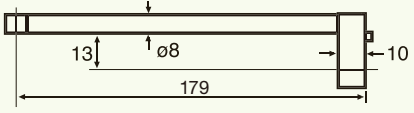
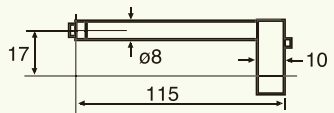
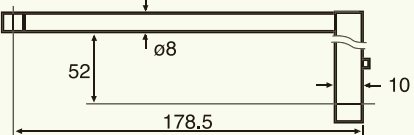
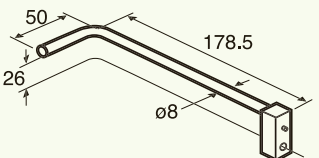
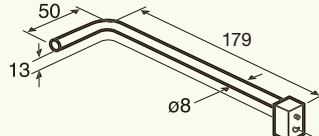
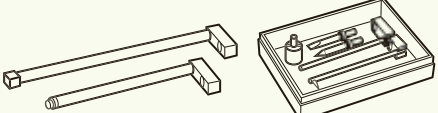









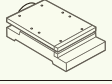

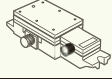

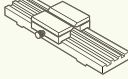

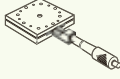
Measuring application	Model	External view	Applicable arm stylus	Remarks
Contour detector	E-DT-CH07A			• C2600, S2800E/G
	E-DT-CH08A			• C2700DX/SD, S2900DX/SD
	E-DT-CH10B			• C1710DX/SD, S1910DX/SD
General purpose	DM45528		DM45502 DM45505 DM45508 DM45523 DM45526	<ul style="list-style-type: none"> • Standard configuration • Deflection: Approx. 1.2 µm for 10 mN Approx. 3.7 µm for 30 mN
Inner surface	DM45529		DM45503 DM45506 DM45509 DM45524 DM45527	<ul style="list-style-type: none"> • Deflection: Approx. 1.2 µm for 10 mN Approx. 3.7 µm for 30 mN
Small holes	DM45530*		DM45510 to DM45521	<ul style="list-style-type: none"> • Stylus combination arm for measuring small holes
Deep grooves	DM45531		DM45501 DM45504 DM45507 DM45522 DM45525	<ul style="list-style-type: none"> • Measuring force: 10 mN or less (Provided with auxiliary weight) • Deflection: Approx. 1.2 µm for 10 mN Approx. 3.7 µm for 30 mN
Offset measurement	DM45532*		DM45502 DM45505 DM45508 DM45523 DM45526	<ul style="list-style-type: none"> • Measuring force: 10 mN or less (Provided with auxiliary weight) • Deflection: Approx. 2.6 µm for 10 mN Approx. 7.8 µm for 30 mN
	DM45533		DM45503 DM45506 DM45509 DM45524 DM45527	<ul style="list-style-type: none"> • Measuring force: 10 mN or less (Provided with auxiliary weight) • Deflection: Approx. 2.6 µm for 10 mN Approx. 7.8 µm for 30 mN
Arm/stylus set	DM45500			<ul style="list-style-type: none"> • Stylus : DM45505, DM45508, DM45513, DM45515 • Arms : DM45530, DM45532

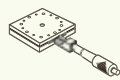
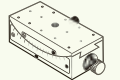
※ Indicates stylus/arm set DM45500

 Standard Inventory Parts

Adjustment Devices

Applicable models ■ S480 ■ S1400 ■ S1500 ■ S2000 ■ S5000 ■ C1600 ■ S1800 ■ C1700/C1710 ■ S1900/S1910 ■ S2000 ■ C2600 ■ S2800 ■ C2700 ■ S2900 ■ SNEX100

Name	Model	External view	Orthogonal axis adjustment (mm)			Swivel adjustment		Tilt adjustment		Table size (mm)	Allowable load (net wt.) (kg)	Remarks
			X	Y	Z	Fine	Coarse	Fine	Coarse			
Adjustment stand	E-AT-S01D		50	50		8 °	360 °			Φ 150	20 (7)	• Min. reading increment 10 μm
Leveling adjustment stand	E-AT-S02A									80 × 110	15 (3)	
Adjustment stand	E-AT-S03A			±2.5		±2 °				80 × 58	3 (0.9)	• For E-RM-S75A
	E-AT-S04A			±8		±3 °				80 × 125	15 (8)	
	E-AT-S05A			±3		±1 °				120 × 58	3 (1.4)	• For E-RM-S76A
	E-AT-S36A			±3		±1 °				200 × 120	5 (4.5)	• For E-RM-S77A
X-direction movement adjustment stand	E-AT-S08A		400							150 × 150	20 (25)	
3D fine adjustment stand	E-AT-S10A		55	55	28					75 × 40	1 (3.4)	• Straightness: 0.03 mm
1-axis precision fine adjustment stand	E-AT-S11B			50						125 × 150	20 (4.9)	• Straightness: 3 μm • Min. reading value: 10 μm
Swivel fine rotation stand	E-AT-S12A					±5 °	360 °			Φ 90	3 (0.58)	• Min. reading value: 5'
1-axis ultra precision fine adjustment stand	E-AT-S13B			10 (Coarse movement: 10 μm Fine movement: 0.5 μm)						60 × 60	10 (0.7)	• Straightness: 3 μm • Min. reading value: 0.5 μm
Tilting stand	E-AT-S64B									60 × 120	10 (1)	• Min. reading value: 5'
Universal stand	E-WJ-S03A						360 °		±90 °	Φ 110	3 (2.5)	• X/Y-direction adjustment
Column rotary spacer	E-CS-S31A ¹				H:100		360 °			—		• Inserted between table and column
	E-CS-S76A ³											
Column spacer	E-CS-S32A ¹				H:200							• Inserted between table and column
	E-CS-S77A ³											
Tracing driver spacer	E-CS-S33A ¹			L : 70								• Inserted between column and tracing driver
Tracing driver tilting device	E-CA-S24A ² E-CA-S85A ³ E-CA-S92A ³									±15 °	—	• For contour measurements E-CA-S85A: For tracing driver 100 mm E-CA-S92A: For tracing driver 200 mm
	E-CA-S32A ²									±5 °	—	• For roughness measurements
	E-CA-S101A ³										(5)	

*1: Cannot be used with S3000A Series and S5000 Series.

*2: Cannot be used for Linear Series and S3000A and S5000 Series. For S1400D,S1800D,S2800E,C1600D,C2600E.

*3: For Linear Series and S1400G, C1600G, S1800G, C2600G, S2800G and S2800G Series.

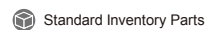

Holders

Applicable models ■ S480 ■ S1400 ■ S1500 ■ S2000 ■ S5000 ■ C1600 ■ S1800 ■ C1700/C1710 ■ S1900/S1910 ■ S2000 ■ C2600 ■ S2800 ■ C2700 ■ S2900 ■ SNEX100

Name	Model	External view	V Holder (mm)	Chucking (mm)	Vice (mm)	Clamp (mm)	Flat surface (mm)	Allowable load (net wt.) (kg)	Remarks
Double-side open vice	E-WJ-S01B				Inside: 59 outside: 38 to 105			5 (0.8)	Consult us when combining with the tilt stand.
V-stand set	E-WJ-S02A		Φ 1 to Φ 150					(1.5)	Provided with workpiece clamber
V-stand holder set	E-WJ-S04A		Φ 12 to Φ 150					(3)	Two pieces used just for T-groove clamp
Compact stand	E-WJ-S05A		Φ 4 to Φ 10					(0.4)	
Load plate	E-WJ-S06A						150 × 150 angle plate	(1)	
Static electricity holding plate	E-WJ-S11A						80 × 130 angle plate	(1.3)	Holding strength 0.2 kg Ideal for paper, aluminum, and film
Scroll chuck	E-WJ-R01C			OD: Φ 2 to Φ 79 ID: Φ 56 to Φ 90				(1)	
Iris chuck	E-WJ-R10A E-WJ-R378A			OD: Φ 5 to Φ 110 OD: Φ 5 to Φ 150				00 (3) 00 (5)	Manufactured after receipt of order
Clamp set	JC-3					Height 40 to 60		-	
Ceramic load plate	E-WJ-S252A						300 × 300 angle plate	(5.3)	Manufactured after receipt of order
	E-WJ-S234A						500 × 500 angle plate	(15)	Manufactured after receipt of order

Standard Inventory Parts

Sample Adjustment Stand/Holder Configurations

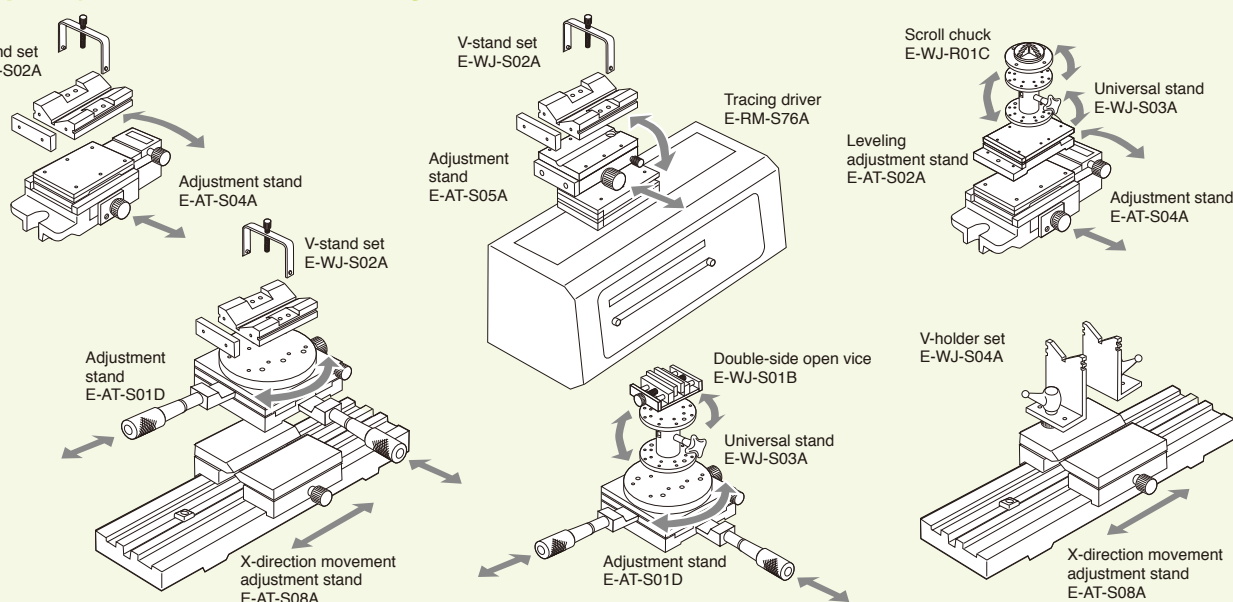

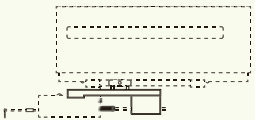
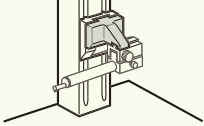
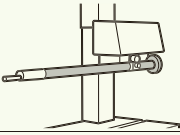
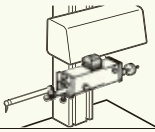
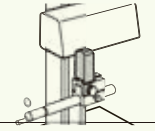
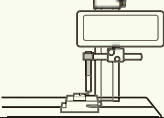
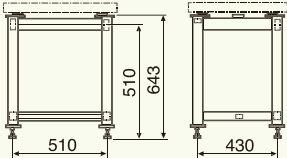
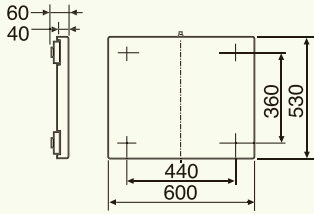
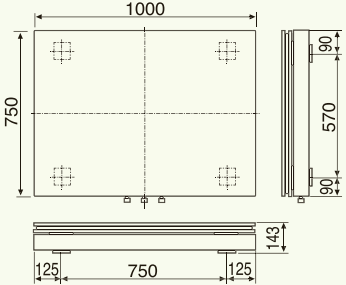
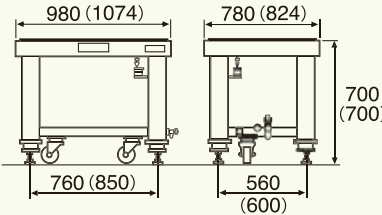

Peripherals

Name	Model	External view	Specifications	Remarks
Pickup movement tracing driver (For standard series)	E-RM-S72B/ S138B		Drive distance: 100 mm Driving speed: 0.03 mm/s to 6.0 mm/s, 8 speeds Straightness accuracy: (0.05 + 1.5L/1000) μm Weight: Approx. 9 kg	<ul style="list-style-type: none"> E-RM-S72B: excluding C2600, 2800 E-RM-S138B: for C2600, 2800 S480: E-RM-S71B Specifications same as shown to left
	E-RM-S178A/ S182A		Drive distance: 200 mm Driving speed: 0.03 mm/s to 6.0 mm/s, 8 speeds Straightness accuracy: (0.05 + 1.5L/1000) μm Weight: Approx. 15 kg	<ul style="list-style-type: none"> E-RM-S178B: excluding C2600, 2800 E-RM-S182B: for C2600, 2800 S480: E-RM-S73B Specifications same as shown to left
	E-RM-S141A		Drive distance: 100 mm Driving speed: 0.003 mm/s to 6.0 mm/s, 11 speeds Straightness accuracy: (0.05 + 1.5L/1000) μm Weight: Approx. 9 kg	<ul style="list-style-type: none"> S480: E-RM-S78A Specifications same as shown to left
Pickup movement tracing driver (For linear series)	E-RM-S205A		Drive distance: 100 mm Driving speed: 0.03 mm/s to 6.0 mm/s Straightness accuracy: (0.05 + L/1000) μm Weight: Approx. 9 kg	
	E-RM-S183E		Drive distance: 200 mm Driving speed: 0.03 mm/s to 6.0 mm/s Straightness accuracy: (0.05 + L/1000) μm Weight: Approx. 15 kg	
Workpiece movement tracing driver	E-RM-S75A		Drive distance: 50 mm Driving speed: 0.03 mm/s to 6.0 mm/s, 8 speeds Straightness accuracy: (0.05 + 1.5L/1000) μm Weight: Approx. 15 kg Load weight: 5 kg Leveling range: ±1.5°	<ul style="list-style-type: none"> Cannot be used for Linear Series. Requires pickup holder stand.
	E-RM-S76A		Drive distance: 150 mm Driving speed: 0.03 mm/s to 6.0 mm/s, 8 speeds Straightness accuracy: (0.05 + 1.5L/1000) μm Weight: Approx. 20 kg Load weight: 5 kg Leveling range: ±1°	<ul style="list-style-type: none"> Cannot be used for Linear Series. Requires pickup holder stand.
	E-RM-S77A		Drive distance: 300 mm Driving speed: 0.03 mm/s to 6.0 mm/s, 8 speeds Straightness accuracy: (0.05 + 1.5L/1000) μm Weight: Approx. 32 kg Load weight: 10 kg Leveling range: ±0.8°	<ul style="list-style-type: none"> Cannot be used for Linear Series. Requires pickup holder stand.
Outer periphery roughness tracing driver	E-RM-S85B		Measuring OD: Φ 12 mm to 20 mm Length: 30 mm to 150 mm OD: Φ 20 to 150 mm Length: 30 mm to 250 mm Peripheral velocity: 0.3, 0.6, 1.5 mm/s Weight: Approx. 7 kg Load weight: 5 kg	
Round surface roughness tracing driver	E-RM-S84A		Measuring radius: 0.25 mm to 40 mm Rotation accuracy: ±0.25 μm (180° arbitrary) Peripheral velocity: 0.3 mm/s (stepless) Weight: Approx. 15 kg	
Column cross feed device	E-ST-S131A		Range of movement : X : 660 mm Y : 200 mm Weight: Approx. 370 kg	For measurement of large and heavy parts (Manufactured upon receipt of order)
Auto tilting table	E-AT-S72A		Leveling range: ±2° Load weight: 5 kg	

Name	Model	External view	Specifications	Remarks
Wide-Range (Hybrid) Detector Holder	E-DH-S182A		Magnification: x5000 or less Straightness: 0.5 μm/100 mm	<ul style="list-style-type: none"> Maximum extrusion: 90mm from left end of driver Column height: 10mm less than normal height For S2000DX/SD
Pickup holder stand	E-CA-S25A		Weight: Approx. 1.5 kg	<ul style="list-style-type: none"> When workpiece movement tracing driver is used
Connecting rod for ultra-long hole measurement	010 2736		Magnification: Up to x10000 Min. inner dia: Up to Φ 25 mm Max. depth: 650 mm Weight: Approx. 1.2 kg Rod diameter: Φ 21.7 mm	<ul style="list-style-type: none"> Used with large measuring stand For measurement of ultra-long holes (Skid measurement) For S480B, S1400G, S1800G, S2800G (0102736) For S1500, S1900G, S1910, S2900 (DM57537)
	DM57537			
Pickup holder coupling	010 2744		Coupling length: 30 mm Weight: Approx. 0.25 kg	<ul style="list-style-type: none"> Used with 010 2804 and 010 2808 contour profile arms Applicable to all models
	010 2745		Measuring depth: Up to 131 mm beneath tracing driver Weight: Approx. 0.47 kg	<ul style="list-style-type: none"> Applicable to all models
Pickup right angle coupling/ connecting rod	010 2746		Measuring depth: 142 mm beneath detector holder Weight: Approx. 0.2 kg Rod diameter: Φ 21.7 mm	<ul style="list-style-type: none"> Pickup vertical measurement using hole bottom stylus
Ordinary stand for desktop anti-vibration table	E-VS-S13A		Dimensions: 510 mm × 430 mm × 643 mm Weight: 22 kg	<ul style="list-style-type: none"> For E-VS-S57A/B, E-VS-S58A
Desktop anti-vibration table	E-VS-S57B		Anti-vibration: Pneumatic diaphragm spring Natural frequency: 2.5 Hz to 3.5 Hz Load weight: 130 kg Dimensions: 600 mm × 530 mm × 60 mm Air source: 350 kPa to 700 kPa Weight: 25 kg	<ul style="list-style-type: none"> With regulator Air tube (external diameter Φ 6) attached.
	E-VS-S58B			<ul style="list-style-type: none"> Air source: Pump
Desktop large anti-vibration table	E-VS-S45A		Anti-vibration: Pneumatic diaphragm spring Natural frequency: 4 Hz Load weight: 300 kg Dimensions: 1000 mm × 750 mm × 143 mm Weight: 80 kg	<ul style="list-style-type: none"> Air source: Pump
Anti-vibration table	E-VS-R16B		Anti-vibration: Pneumatic diaphragm spring Natural frequency: V: 2 Hz; H: 2.2 Hz Load weight: 250 kg Dimensions: 980 mm × 780 mm × 700 mm Air source: 350 kPa to 700 kPa Weight: 170 kg	<ul style="list-style-type: none"> With regulator
	E-VS-S21B			<ul style="list-style-type: none"> With regulator

*3 If retrofitted to S2000 and SNE100, correction value needs to be obtained again.

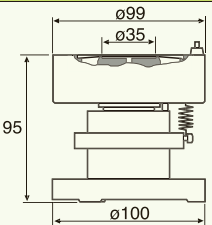
Name	Model	External view	Specifications	Remarks
System rack	E-DK-S24A		Dimensions: 800 mm × 800 mm × (1070 to 1370) mm Weight: 44.5 kg	
	E-DK-S25A		Dimensions: 1200 mm × 800 mm × (1070 to 1370) mm	
Side desk	E-DK-S10A		Dimensions: 400 mm × 700 mm × 700 mm	
High magnification dust cover	E-CV-S02A		Dimensions: 750 mm × 614 mm × 810 mm Weight: 8 kg	<ul style="list-style-type: none"> Used with desktop anti-vibration table/stand for roughness measuring For Standard/Linear series SD type (Excluding S5000, S3000)
	E-CV-S03A		Dimensions: 1000 mm × 629 mm × 810 mm Weight: 13 kg	<ul style="list-style-type: none"> Used with desktop anti-vibration table/stand for contour profile measurement For Standard/Linear series SD type (Excluding S5000, S3000)
Dust cover	E-CV-S25A		Dimensions: 1070 mm × 750 mm × 1050 mm Weight: 20 kg	<ul style="list-style-type: none"> Used with E-VS-S21A anti-vibration table for large measuring table
Measuring position verification unit	E-MA-S81A		Magnification: x20 Focal distance: 60 mm	<ul style="list-style-type: none"> Stand type
	DM59014		Magnification: x20 Focal distance: 60 mm	<ul style="list-style-type: none"> Can be used with workpiece movement tracing driver
Light	E-MA-S84A			<ul style="list-style-type: none"> Stand type
Color camera monitoring system	DM59103		Image sensor: Interline type CCD Effective pixels: 768 mm × 494 mm	Configuration (1) Color camera (2) Color monitor (3) Power adapter (4) Microscope adapter (5) Connection cable (6) Instruction manual

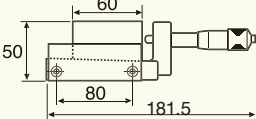
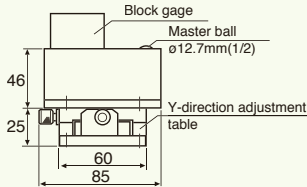
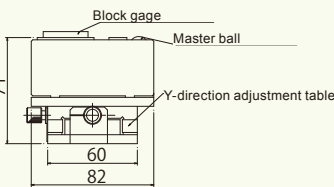
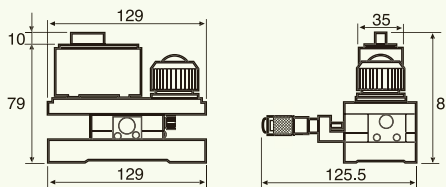
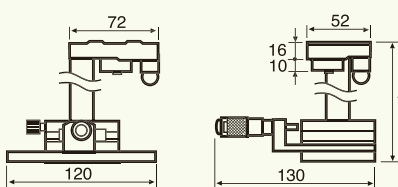
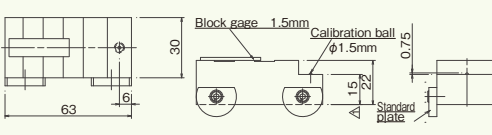
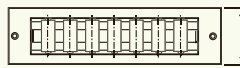
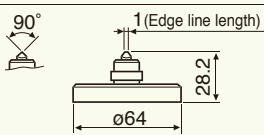
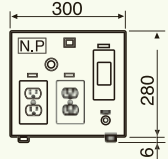
Name	Model	External view	Specifications	Remarks
Tape tension jig	DM58526			<ul style="list-style-type: none"> For pickup movement tracing driver
Reference specimen	E-MC-S24B		Calibration surface: Approx. 3.1 μm Ra Stylus check surface: Approx. 0.4 μm Ra Measured value described.	<ul style="list-style-type: none"> For sensitivity calibration and for checking stylus Applicable to JCSS calibration and NIST calibration
Level difference reference specimen	E-MC-S57A		Large range: Approx. 20 μm Small range: Approx. 2 μm Measured value described.	<ul style="list-style-type: none"> Standard accessory for linear series roughness system For detector sensitivity calibration and stylus check Applicable to JCSS calibration
Magnification calibrator	E-MC-50C		Narrow range accuracy: 0 to 10 μm ±0.1 μm Wide range accuracy: 0 to 400 μm ±1.0 μm	<ul style="list-style-type: none"> For magnification calibration
Master ball calibration unit	E-MC-S34A			<ul style="list-style-type: none"> For measurements with stylus pointing downwards Standard accessory for C1600D/G, C2600E/G, C1700DX/SD, C2700DX/SD
	E-MC-S65A			<ul style="list-style-type: none"> For measurements with stylus pointing downwards Standard accessory for S2000DX/SD, SNEX100
	E-MC-S48A		Master ball calibration unit	<ul style="list-style-type: none"> For measurements with stylus pointing downwards Standard accessory for S3000A, S5000DX/SD
	E-MC-S51A			<ul style="list-style-type: none"> For measurements with stylus pointing upwards For C2600E/G, S3000A, C2700DX/SD, S5000DX/SD
	E-MC-S59D		Block gage: 1.5 mm Reference sphere: Φ1.5 mm	<ul style="list-style-type: none"> For measurements with stylus pointing downwards and stylus for small bore measurement For C1600, C1700DX/SD, C2600, S3000A For C2700DX/SD, S2000DX/SD, S5000DX/SD, S2000, SNEX100
Pitch gage	E-MG-S02A		Pin diameter: 7.9 mm Pitch: 15 mm Dimensions: 144 mm × 38 mm × 49 mm	
Stylus check master	E-MG-S24A		Tip radius: 0.1 μm or less Material: Knife edge diamond	
Power transformer box	E-TF-R25A		Input: 90 V to 240 V Output: 100 V Capacity: 2.1 kVA Dimensions: 300 mm × 350 mm × 296 mm Weight: 45 kg	<ul style="list-style-type: none"> Specify the input voltage

Accessories for SURFCOM 130A, FLEX-50A

Name	Model	External view	Specifications	Remarks
Compact measuring stand	E-ST-S130A		Table size: 410 mm × 200 mm Max. measuring height: 200 mm Weight: Approx. 18 kg Load weight: 20 kg	<ul style="list-style-type: none"> Tracing driver height and tilt can be adjustable depending on a size and form of a workpiece
Pickup	E-DT-SE18A		5 μm R90° conical diamond, 4mN	<ul style="list-style-type: none"> All orientations Horizontal tracing possible With 0102501 stylus For S130A, S-FLEX50A
	E-DT-SE19A		2 μm R60° conical diamond, 0.7mN	<ul style="list-style-type: none"> Standard accessory
Touch pen	E-MA-S54A			<ul style="list-style-type: none"> Specialized for S130A, S480A/B
Battery set	E-MA-S65A		<ul style="list-style-type: none"> Battery charger for 130A Size: 80 mm × 85 mm × 45 mm Weight: Approx. 400g Charging time: 4 hours 	Measurements and recording are available on-site where there is no power source
			<ul style="list-style-type: none"> Battery for 130A Size: 203 mm × 58 mm × 67 mm Weight: Approx. 1.2g 	Contents: AC adapter, battery charger, battery
Roll foot	E-MA-S62A			<ul style="list-style-type: none"> Attachment for placing the tracing driver on a roll shaped object for measurement Roll outer diameter: Φ 60 mm or more
	E-MA-S63A			<ul style="list-style-type: none"> Photo shows unit of E-MA-63A Roll outer diameter: Φ 60 mm or more
Dust proof cover	E-MA-S64A			<ul style="list-style-type: none"> For Amplification indicator Specialized for S130A, S480A/B
All position pickup holder	E-DH-S107A			<ul style="list-style-type: none"> For measuring surface roughness of slanted surfaces, vertical surfaces, ceiling surfaces and other non-flat surfaces
Horizontal tracing pickup holder	E-DH-S17A			<ul style="list-style-type: none"> Attachment for horizontal tracing of items, such as crankshafts which have obstacles in the front and back in the measuring direction (using double-side straddling skid)
Attachment for tracing driver	E-CA-S62A			<ul style="list-style-type: none"> 50 mm tracing driver attached to manual column (E-CL-S26A)
RS-232C cable	E-SC-S288A		Support 9pin Windows PC	<ul style="list-style-type: none"> Cable connected Specialized for S130A
CF card + adaptor	E-MU-S50C		128 MB	<ul style="list-style-type: none"> Provides registrations of approx. 500 measurement conditions and storage of approx. 500 measurement data (200 text management items) For 130A

Accessories for HANDYSURF E-35B, 40A, 45A and SURFCOM FLEX-35B, 40A, 45A

Name	Model	External view	Specifications	Remarks
Pickup	E-DT-SM10A E-DT-SM49A E-DT-SM39A		5 μm, 90° conical diamond, 4 mN (For 35B · 40A) 2 μm, 90° conical diamond, 0.75 mN (For 35B · 40A) 5 μm, 90° conical diamond, 4 mN (For 45A)	<ul style="list-style-type: none"> For general measurement Standard accessory
	E-DT-SM11A E-DT-SM50A		5 μm, 90° conical diamond, 4 mN (For 35B · 40A) 2 μm, 90° conical diamond, 0.75 mN (For 35B · 40A)	<ul style="list-style-type: none"> For fine hole Min. inner diameter: Φ 5 mm
	E-DT-SM12A E-DT-SM51A		5 μm, 90° conical diamond, 4 mN (For 35B · 40A) 2 μm, 90° conical diamond, 0.75 mN (For 35B · 40A)	<ul style="list-style-type: none"> For extra fine hole Min. inner diameter: Φ 3 mm
	E-DT-SM13A E-DT-SM52A		5 μm, 90° conical diamond, 4 mN (For 35B · 40A) 2 μm, 90° conical diamond, 0.75 mN (For 35B · 40A)	<ul style="list-style-type: none"> For deep groove Max. depth: 7 mm
Reference specimen	E-MC-S24B		Calibration surface: Approx. 3.1 μmRa Stylus check surface: Approx. 0.4 μmRa Measured value described	<ul style="list-style-type: none"> For sensitivity calibration and stylus check Standard accessory
Adjustment device (Rear)	E-WJ-S64A			Standard accessory for 35B, 40A
	E-WJ-S559A			Standard accessory for 45A
Adjustment device (Front)	E-WJ-S80A			For 35B, 40A
	E-WJ-S560A			For 45A
Nose piece (Cylinder)	E-WJ-S85A			For 35B
	E-WJ-S562A			For 35B, 40A
Nose piece (Flat)	E-WJ-S88A			For 35B
	E-WJ-S561A			For 35B, 40A
Nose piece (V-shape)	E-WJ-S536A			Standard accessory for 45A
Nose piece (contact type)	E-WJ-S563A			For 45A
Extension adapter for long hole	DM57506			For 35B, 40A
Adapter for horizontal measurement	DM57507			2 or more adaptors cannot be used. For 35B, 40A
Adapter for bore measurement	E-WJ-S86A		Place a central pin on a lower bore	For 35B, 40A

SURFCOM: CONTOURCORD
Option

Accessories for HANDYSURF E-35B, 40A, 45A and SURFCOM FLEX-35B, 40A, 45A

Name	Model	External view	Specifications	Remarks
Holder for tracing driver	E-MD-S200A		Mounted on side of FLEX amplifier	• For FLEX-35B, 40A
Magnetic stand	E-ST-MAC			
Post mount holder	010 2050			
Post mount	E-CS-S26A			• For Φ 6
Adapter for height gage	E-WJ-S93A		Cross-section surface on scribe of height gage: 9 mm × 9 mm	• Used with post mount, E-SC-S26A
RS-232C cable	E-SC-S366A		Support 9 pin Windows PC	• With sample program for communication
	USB-RS adapter			• Used with E-SC-S366A in case PC has no RS port

Consumables

Name	Model	External view	Specifications	Remarks	摘要
CF card + adaptor	E-MU-S50C		130A, 480B		• 128MB Provides registrations of approx. 500 measurement conditions and storage of approx. 500 measurement data (200 text management items)
Recording paper	E-CH-S21A		130A, 480B		• 10 rolls/box • External diameter: Φ 47 mm, external width: 58 mm, roll length: 25 m
		E-RC-S24A	High-speed printer for E35A, E35B, E40A, E45A		
	E-CH-S25A	E-RC-S23A E-RC-S25A E-RC-S29A	Compact printer for E35A, E35B, E40A, E45A built-in printer for FLEX, compact printer II for E35A/B, E40A, E45A		• 10 rolls/box • External diameter: Φ 24 mm, external width: 58 mm, roll length: 7 m
		E-CH-50A	E-RC-S01A/B	100B, 300B, 400B, 500B, 700B, 720B 550A, 900A/B, 920A, 730A, 470A, 740A	
	E-RA-S01A		200B		
	E-RA-S03A		200C		
	E-CH-S05B		570A, 590A, 750A, 790A		• 10 rolls/box • External diameter: Φ 58 mm, external width: 60 mm, roll length: 40 m
		E-RC-S09A	440A, 470A, 740A, 900B, 920B		
	E-CH-S02A		110A, 350A, 550A, 470A 730A, 740A, 920		• 20 rolls/box • External diameter: Φ 50 mm, external width: 68 mm, roll length: 25 m
	JIS No.121	E-RC-XY16	600B/C/D		• 100 sheets/leaflet • A3 leaflet
E-CH-S26A	E-RC-S30A	Compact printer III for E35B, E40A, E45A		• 10 rolls/box • External diameter: Φ 38 mm, external width: 58 mm, roll length: 19 m	
Ink ribbon	E-IR-S01A		110A, 110B, 350A, 550A, 470A 730A, 740A, 920A		

 Standard Inventory Parts